

350DNC40-24 Series

DC-DC Converter

Bel Power Solutions **350DNC40-24** is a 4 kW DC/DC Converter Series that creates DC voltages in hybrid and electric vehicles suitable to power low voltage accessories.

Liquid cooled or convection cooled DC/DC converter operates at input voltages from 240 to 430 VDC or 300 to 450 VDC and delivers power range up to 4000 W / 3300 W (liquid / convection cooled model).

Features include very high efficiency, high reliability, low output voltage noise, and excellent dynamic response to load/input changes.



Key Features & Benefits

- Very high efficiency up to 93 %
- Input voltage range: 240-430 VDC (300-450 VDC)
- Up to 4 kW power
- Full galvanic isolation between input and output
- Liquid or convection cooled models available
- CAN bus serial interface
- Adjustable output voltage
- Over temperature, output overvoltage and overcurrent protection, input and output reverse polarity protection
- Protection degree IP65 and IP67
- E-MARK E13*10R00*10R05*13602*00

Applications

- Hybrid and Electric Vehicles

1. MODEL SELECTION

MODEL	DESCRIPTION
350DNC40-24-8G	Liquid cooled model
350DNC40-24-CG	Convection cooled model
300DNC40-24-8S419	Liquid cooled model
350DNC40-CON-KIT-8G	Mating connectors kit – Signal connector housing and pins, HV connector assembled with 3 m cable
350DNC40-CON-KIT-9G	Mating connectors kit - housing and pins

2. INPUT

PARAMETER	DESCRIPTION / CONDITION	MIN	NOM	MAX	UNIT
Input Voltage	350DNC40-24-8G, 350DNC40-24-CG	240	350	430	VDC
	300DNC40-24-8S419	300		450	
Input Current	350DNC40-24-8G, 350DNC40-24-CG			19	ADC
	300DNC40-24-8S419			16	
Efficiency	@ Vin = 350 VDC, Vo = 28 V, I _{nom} = 143 A	92			%
Input Line Interruption	Converter shutdown	350DNC40-24-8G, 350DNC40-24-CG		240	VDC
		300DNC40-24-8S419		300	
Input Capacitance			30		µF
Inrush Current	External pre-charging circuit required				

3. OUTPUT

PARAMETER	DESCRIPTION / CONDITION	MIN	NOM	MAX	UNIT
Output Voltage	Vo to be trimmed via CAN BUS, 10 bit resolution	22	28	32	VDC
Output Current	Liquid cooled model		143		ADC
	Convection cooled model		120		
Output Power	Liquid cooled model			4000	W
	Convection cooled model			3300	
Line Regulation	V _{inmin} - V _{inmax} , @ 60 A, T _{coolant} = 70°C	- 0.10		+ 0.10	VDC
Load Regulation	I _{out} 10 to 90% load, T _{coolant} = 70°C	- 0.15		+ 0.15	VDC
Output Voltage Set Point	@ 60 A, T _{coolant} = 25°C	27.9	28	28.1	VDC
Thermal Drift		-0.05		+0.05	%/°C
Periodic and Random Deviation	@ 28 VDC / Nominal load (Differential Mode 20 MHz)			460 *	mVp-p
	CAN high / low (Differential Mode 20 MHz)			300 *	
Transient Response	Load step 1: 10 to 50 % and back				
	Load step 2: 50 to 100 % and back				
	Voltage over/under shoot:	-1400		+1400	mV
	Response time within 1 % of VoSET:			1000	µs
Turn-on Overshoot	V _{onom} , <100 ms			5	%
Redundant Parallel Operation	Up to 4 converters operating in parallel			16	kW
Remote Sense	Cable Drop (V) @ Maximum Load			0.5	V
Turn-On Delay	Rise time (C _{ext} = 0 µF)			200	ms
	Power-on-delay (From applying DC input voltage to Vo=90 %)			1	s
	Power-on-time from PS_WAKE UP (From PS_WAKE UP ON to Vo = 90% of nom)			3	s
Turn-Off Timing	PS_WAKEUP delay; (monotonic Vo fall)	0		100	ms
Capacitive Load	@ 28 VDC		0	7200	µF

* With external capacitors 47 µF (Electrolytic cap) & 1 µF (X7R Ceramic cap) connected to measuring point

4. PROTECTION

PARAMETER	DESCRIPTION / CONDITION	MIN	NOM	MAX	UNIT
Output Over-Current Protection	Constant current Liquid cooled model Convection cooled model		146 123		A
Output Over-Voltage Protection	Latch type, max. O V duration 1ms	32		36	V
Output Under-Voltage Protection	Max. UV duration 1s, then hiccup	18		20	V
Over-Temperature Protection	Converter shutdown Liquid cooled model Convection cooled model	80 50			°C
Input and Output Reverse Polarity Protection	Protective elements connected in series				
Input Fuse Protection	DC Input: internal primary fuse		25		A
Input Low Line Protection	Turn ON threshold Turn OFF threshold	250 235	255 240	260 245	VDC
Input Overvoltage Protection	Recovery: Vin re-cycling or PS_WAKEUP 350DNC40-24-8G, 350DNC40-24-CG 300DNC40-24-8S419	435 455		450 465	V

5. INTERFACE & CONTROL SIGNALS

PARAMETER	DESCRIPTION / CONDITION	CRITERION
CAN BUS SAE J1939	250 kBit/s or 500 kBit/s available	
Remote Sense Signals	Sense positive (+ SENSE) Sense negative (- SENSE)	0.5 V compensation
Address Bits	Internally pulled up to LOGIC HIGH (3.3V 100kohm)	Adr. 0 Adr. 1
PS_WAKEUP	Logic input signal	+24 V
HVIL function	HVIL pins shorted internally	Part of HV connector
CAN_SPEED	CAN speed selection Internally pulled up to LOGIC HIGH (3.3V 100kohm)	Logic Low – 250kBit/s Logic High – 500kBit/s

6. SAFETY, REGULATORY & EMC SPECIFICATIONS

PARAMETER	DESCRIPTION / CONDITION	CRITERION
Safety certification	Report number: E13*10R00*10R05*13602*00	E-MARK
Insulation	Basic: 3000 VDC Basic: 3000 VDC	Input-to-Protective Earth Input-to-Output
Radiated Emission	UN ECE R10 4th Edition	ESA level
Electrostatic Discharge	IEC 61000-4-2	Performance Criterion B
Radiated Electromagnetic Field	IEC 61000-4-3 (10 V/m), SAE J1113/21(100V/m)	Performance Criterion B Class B
Electrical Fast Transient	IEC 61000-4-4, Level 2 (+/-2 kV, 2.5 kHz) ISO 7637-2; ISO 7637-3, ISO 16750-2	Performance Criterion B
RF Conducted Immunity	Level 3 (10 V, 0.15...80 MHz, AM 80%, 1kHz)	Performance Criterion A
RF Disturbances Immunity	SAE J1113-41 ISO11452-4 (1-400 MHz, 60 mA)	Class A Class B

7. CONNECTORS

PARAMETER	DESCRIPTION / CONDITION	MANUFACTURER	MPN
Input Connector (IN)	High voltage connector with HVIL function	TYCO	2103124-1, KEY A
Output Connector (OUT)	Male dual terminal thread M8		
CAN BUS and Signal Interface (CTRL)	Panel mounted	TYCO	776276-1

Signal Connector Pin Description

PIN	SIGNAL DESCRIPTION
1	PS_WAKEUP
2	ADR0
3	ADR1
4	CAN_SPEED
5	CAN_H
6	CAN_L
7	+SENSE
8	-SENSE

Signal Connector

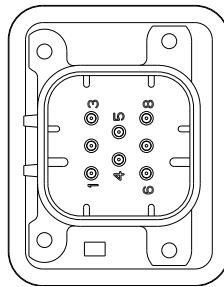

Output Connector

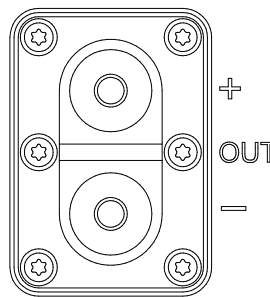

Input Connector

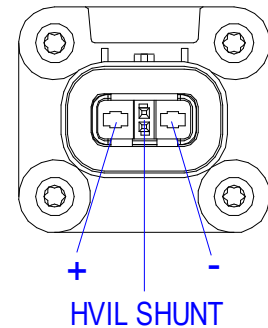

8. ENVIRONMENTAL SPECIFICATIONS

PARAMETER	DESCRIPTION / CONDITION	MIN	NOM	MAX	UNIT
Altitude	Operating: 62 kPa absolute pressure			3600	m
	Non-Operating: 18.6 kPa absolute pressure			12200	
Operating Temperature	Liquid cooled: T_coolant with no derating	-40		+70	°C
	T_amb @ full load, with no power derating	-40		+85	
	Convection cooled: T_amb with no power derating	-40		+45	
Storage Temperature		-40		+95	°C
Humidity	SAE J1455				
Shock	SAE J1455				
Vibration	SAE J1455, MIL-STD-202G				

9. COOLING SPECIFICATIONS

PARAMETER	DESCRIPTION / CONDITION
Maximum Inlet Coolant Temperature	+70°C
Coolant Medium/Mixture	50/50 Propylene or Ethylene Glycol/Water
Min. Coolant Flow	0.0208 l/s (0.33 GPM)
Max. Coolant Flow	0.1166 l/s (1.85 GPM)
Max. Coolant Pressure	20 psi
Max. Pressure Drop	1 psi

10. MECHANICAL SPECIFICATIONS

PARAMETER	LIQUID COOLED MODEL	CONVECTION COOLED MODEL
Dimensions (W x H x D)	270 x 113 x 341.5 mm	350 x 187 x 341.5 mm
Weight	11 kg	22 kg
Enclosure	IP65 and IP67	

350DNC40-24 Series

Mechanical Drawings - Liquid Cooled Model

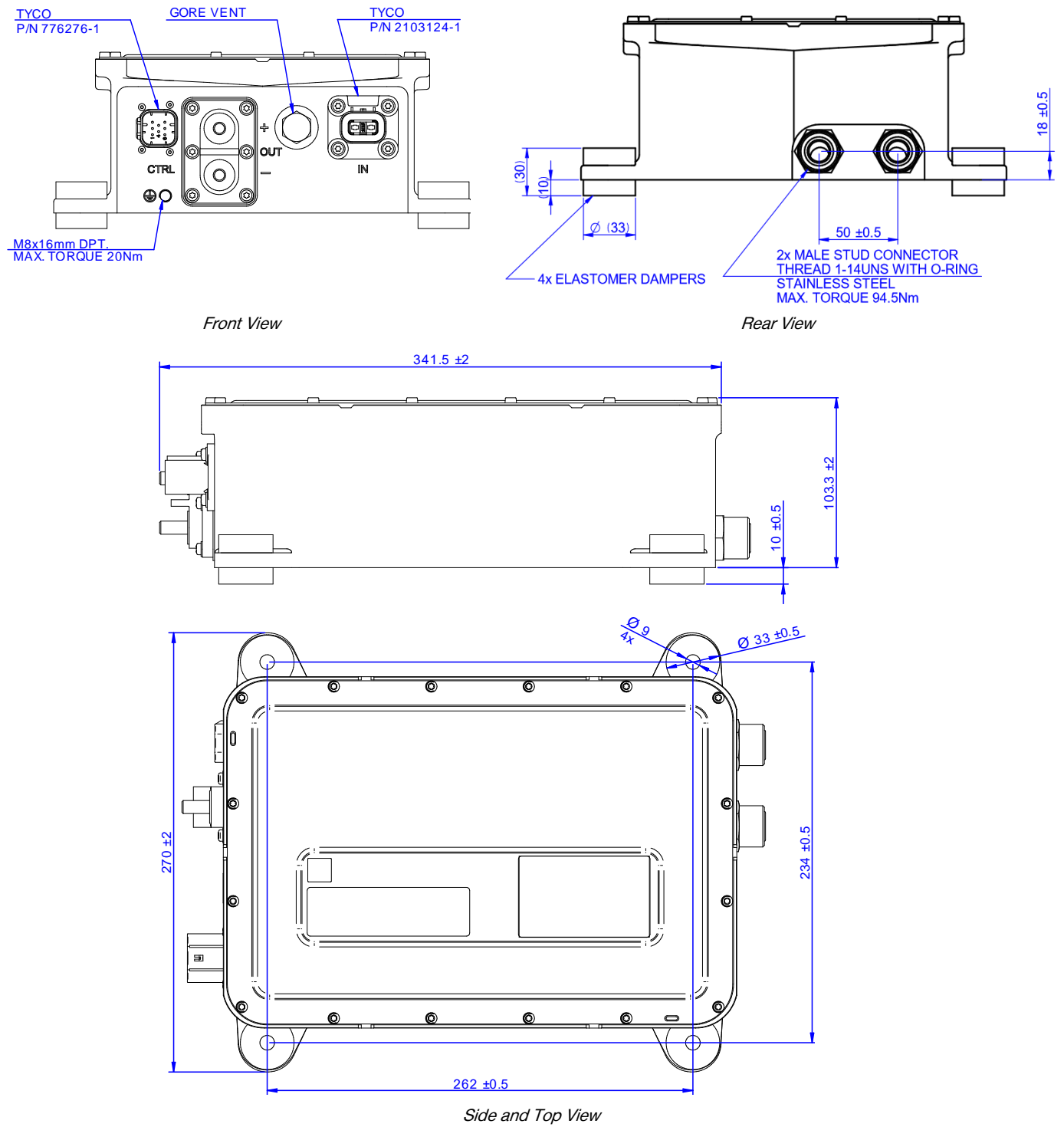

Mechanical Drawings - Convection Cooled Model

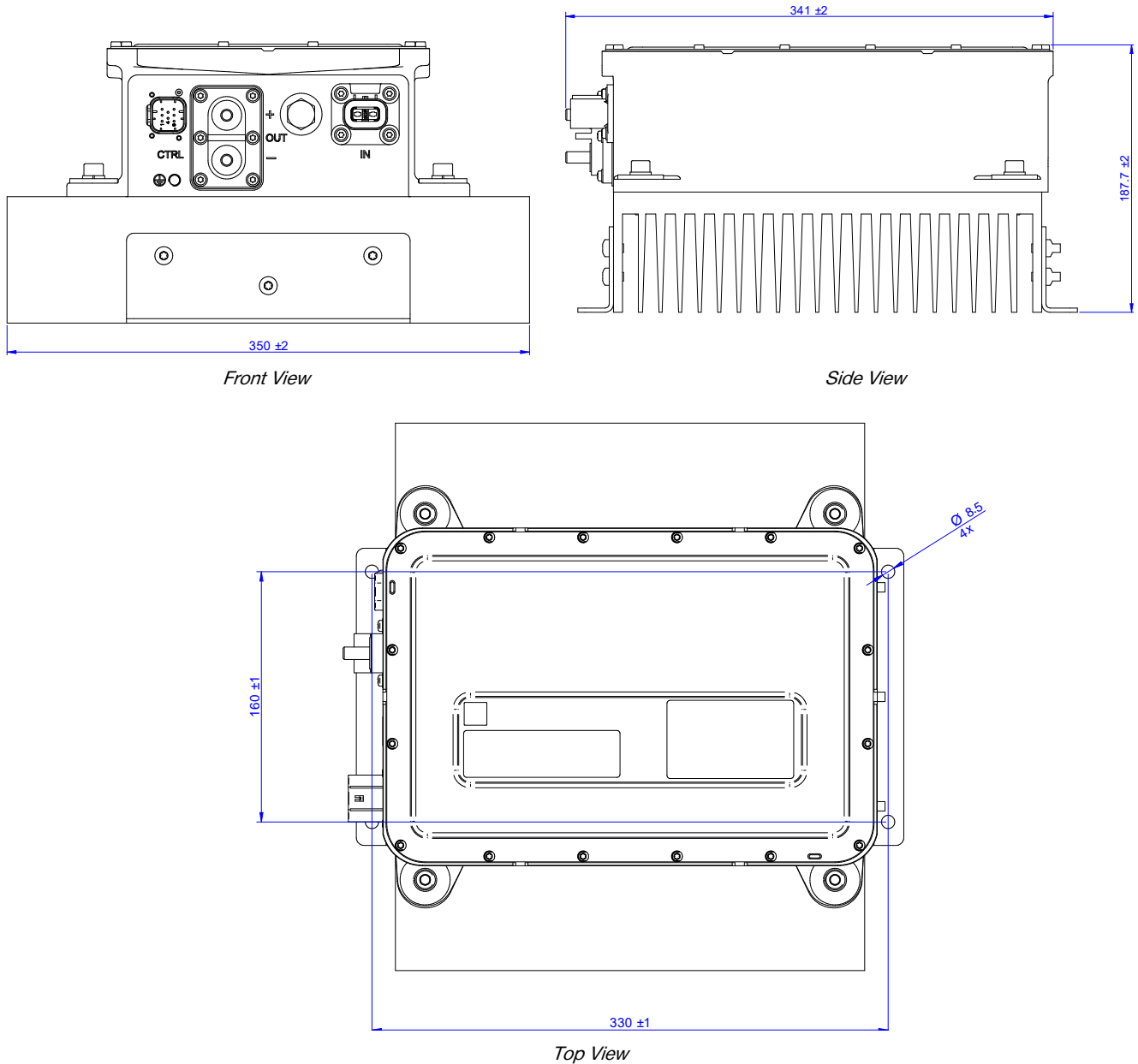

For more information on these products consult: tech.support@psbel.com

NUCLEAR AND MEDICAL APPLICATIONS - Products are not designed or intended for use as critical components in life support systems, equipment used in hazardous environments, or nuclear control systems.

TECHNICAL REVISIONS - The appearance of products, including safety agency certifications pictured on labels, may change depending on the date manufactured. Specifications are subject to change without notice.